

Mixed Gas Re-Metering

Some production processes gain substantial quality and yield improvements through mixed gas re-metering. Historically, there have been few technologies that can support mixed gas re-metering, particularly in flows below 20SLPM or operating at low pressures. One solution uses Alicat's mass flow meters in combination with the Wilke Semi-empirical method for mixed gas viscosity calculations.

Mixed gas re-metering is different from a gas mixture calibration. In gas mixture calibrations sufficient accuracies ($\pm 1\%$ f.s.) can be obtained by using the actual gas mix in the calibration. In mixed gas re-metering the actual gas mixture is constantly changing as part of the production process.

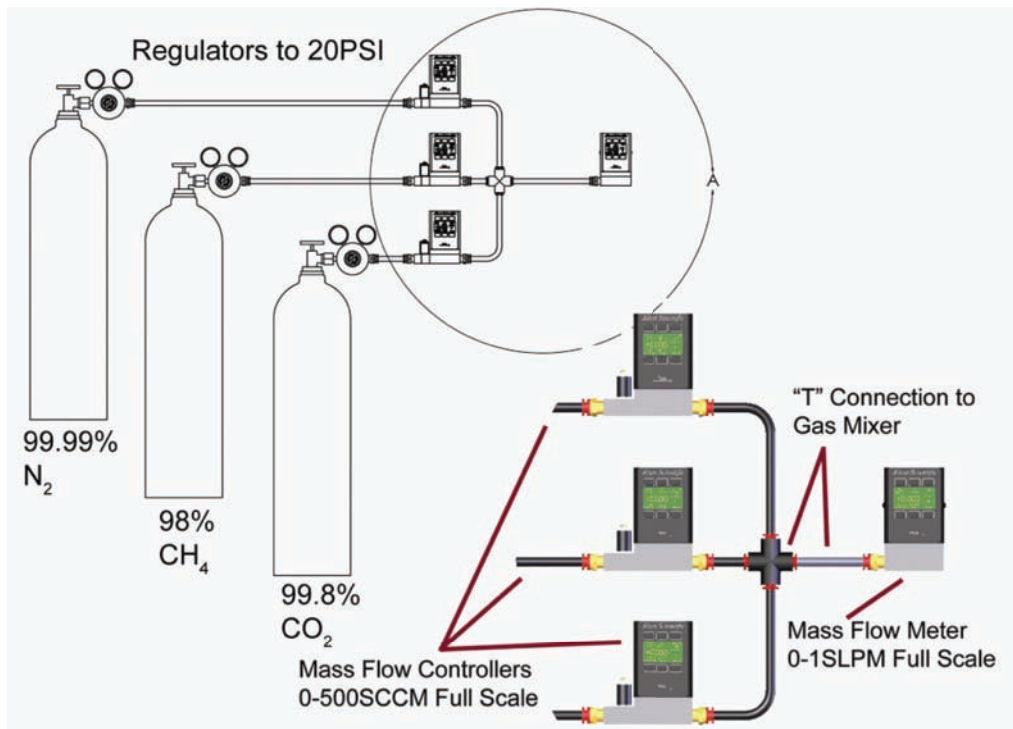

The diagram demonstrates three mass flow controllers (MFCs) regulating gases from individual tanks into a simple mixing tube. Next a mass flow meter (MFM) re-meters the gas mix. Each MFC has been set to the appropriate pure gas calibration using the gas select screen. The MFCs are receiving their fluctuating flow control ratios by the PC. The MFM is set for N₂ as a calibration reference point. The PC reads the MFM's indicated flow and performs some simple ratio corrections to determine the actual gas flow for the mixture.

To perform the ratio corrections, the PC uses the MFC's set-points to determine the percent of each gas in the resulting mixture. Next, the computer calculates the theoretical gas mixture viscosity using Wilke's equation. Finally, the PC determines the actual gas flow by performing a simple viscosity ratio correction on the indicated flow:

Actual Flow = Indicated Flow at N₂ Viscosity / Calculated Mix Viscosity

Laboratory tests have demonstrated an overall $\pm 3\%$ of reading accuracy for this technique. The engineers at Alicat Scientific have spreadsheets with the appropriate Wilke's calculations and viscosity look-up tables to simplify incorporating this method into an existing field PC. It should be noted that Wilke's method works best on gases operating below 125PSIG and 50°Celsius. It is possible to use methods other than the Wilke's equation for a re-metering system. If incorporating Alicat's mass flow devices it is crucial that the alternate mathematical model solves for viscosity, not thermal coefficients.